



JAMES HENRY
BEAUTIFUL TIMBER FLOORS

THE ART OF OAK



French Oak Stave Parquet floor in The Petit Tasting Room, Martinborough

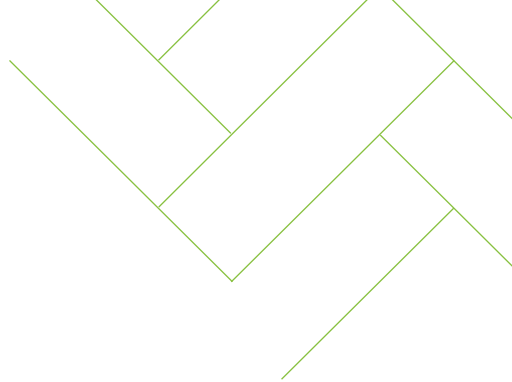

CONTENTS

About James Henry	4
Awards	5
Why Choose an Oak Floor	6
Oak Grades	6
Colours and Finishing	7
Engineered Oak T&G	9
Solid Oak T&G	11
Oak Parquet Floors	13
French Oak Stave Parquet	15



ABOUT JAMES HENRY

We are based in the Wellington Region and specialise in the supply and installation of high quality wooden floors. We have a great team of experienced and hardworking tradesmen, our overriding aim is to ensure our customers get a beautiful and classic floor. A floor which has been installed correctly, adds value and will provide many years of service.



WE EMBRACE DIVERSITY

- We have staff from nine different cultures or countries.
- We have provided employment to refugees who have recently arrived in New Zealand, prisoners on a release to work program, prisoners on parole, intellectually disabled people and people with learning difficulties.



WE ARE ACTIVE IN OUR COMMUNITY

- We deliver untreated wood shavings to three community vegetable gardens.
- We actively support the food and community charity Common Unity, based in Eponi with donation of time, volunteers and food.
- Staff get paid time off to donate blood.



WE ENCOURAGE HEALTHY LIVING

- We have run stop smoking incentives and have engaged a stop smoking coach.
- We mentor our staff around financial planning and into home ownership.
- We have a life coach and counsellor who works with those who need a mental health check up.
- Our best staff started with us as workshop labourers, undertook apprentice training, and are now in leadership positions.
- We've had twelve people complete apprentice training with us since 2010.
- Staff turnover is extremely low.



OUR WORK IS AWARD WINNING

The quality of our work and the dedication of our team has been recognised through multiple awards over the years.



Wellington Region Business Excellence Awards

We are proud to say that James Henry achieved **first-place wins** in the **Trade Services and Suppliers** category in 2019, 2018 and 2016, and were finalists in 2022. As well as this we were awarded as **winners in the Sustainability category** in 2018 and 2014.

This followed on from first place wins in the 2014 Wellington Business Excellence Awards from the Innovation and Best Emerging Business categories.

Note: These awards were not held in 2020 and 2021.



Australasian Timber Flooring Association Annual Awards

The Australasian Timber Flooring Association is the peak body for timber flooring professionals in NZ and Australia.

In 2016, 2017 and 2018 we achieved **first place category wins**, including a recycled parquet floor in a house in coastal Taranaki, and for our work at Te Papa, Wellington.

In 2017, we **won the overall Supreme Award** for our work at St Mary of the Angels in Boulcott Street, Wellington.

Note: These awards were not held in 2020 and 2021

WHY CHOOSE AN OAK FLOOR?

Oak is an excellent choice for a wooden floor. It is durable, stable, sustainably sourced, looks great and it is a beautiful 'canvas' if you'd like to choose a coloured finish. Clear finishes such as Hardwax Oil or Water based polyurethane also look great on Oak.

Oak has been used for wooden floors in Europe and America for centuries. It is available as solid floorboards (usually American White Oak) or Engineered floorboards (usually European Oak), as well as parquet flooring (in solid Oak and engineered Oak).

Our range of Oak flooring can be finished in place or supplied and fitted as pre-finished flooring. We will work with you to design and install a beautiful Oak floor, whether that is a solid American White Oak floor, an Engineered European Oak floor, or an elegant Oak Parquet floor.

TIMBER GRADES

Oak is available in different grades ranging from clear to very featured. Here at James Henry, we prefer Oak floors with more character and feature. This creates a timber floor that actually looks like a timber floor. We like to celebrate the organic beauty of the magnificent Oak tree, with all it's knots, grain and ray-like patterns.

Feature grade floors show off the natural beauty of the wood. With larger and more frequent knots and natural features, as well as more colour variation, feature grade timber is full of charm and warmth. This grade tends to suit traditional homes or anywhere texture is being used to create an inviting feeling.

Prime grade floors are more uniform in appearance, with fewer and smaller knots, and a more consistent colour. This grade tends to suit modern spaces where a sharp look is sought.



Example of Select grade



Example of Feature grade

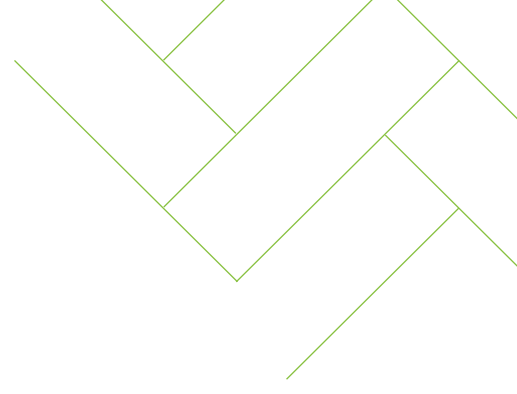

FINISHING OPTIONS

We finish our floors with Rubio Monocoat 2C Oil or a water based polyurethane. Both of these finishes are hard wearing and suitable for all areas of the home, including kitchens, laundries and powder rooms.

The Rubio Monocoat range enhances the natural look and feel of the wood, has zero VOCs, is water and heat resistant and easy to maintain. This finish choice is also food safe, which is a great assurance for those with children and pets. There are over 40 standard colours in the Rubio Monocoat 2C oil range.

Water based polyurethanes are now well developed and durable. There is a range of gloss levels available including velvet and matte options.

COLOUR RANGE

Our colours options for Oak flooring have been carefully curated to deliver a varied and classic mix of tones for any home – as well as showcase the beautiful grain and features of the Oak timber. We can also create custom colours or colour match on request.



Chalk



Latte



Light Oak

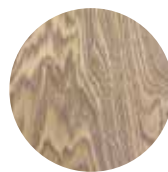

Oyster

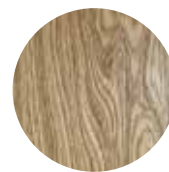

Warm Oak



Walnut



Pebble Grey



Sand Dune



Antique Oak



Peppercorn



Slate Grey

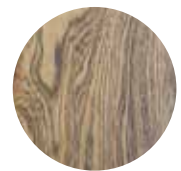

Ash Grey



Sundance

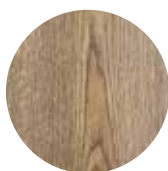

Cashmere Brown

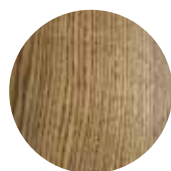

Castle Brown



Chocolate



Pecan



Mystic Dark



Engineered European Oak floor, finished in a custom Rubio colour



ENGINEERED EUROPEAN OAK

Our Engineered European Oak flooring is pre-finished in the workshop. You can choose from one of 16 colours in our Classic colour range, or we can create a custom colour just for you.

Choosing an Engineered European Oak floor is a great way to achieve a stunning Oak floor, with the convenience of it being laid pre-finished.

Our standard board widths are 190, 220, 240 and 300mm, so you can select the look that best suits your project's interior.

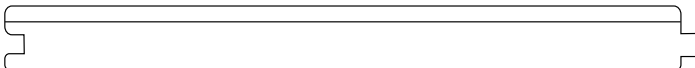
With a contemporary lightly brushed texture and micro-bevel detail, our Engineered European Oak flooring is an attractive flooring solution that will impress.

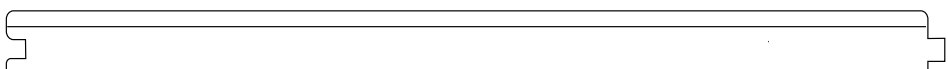
4mm Oak Layer	190mm x 15/4mm 	S
6mm Oak Layer	220mm x 20/6mm 	J S
6mm Oak Layer	240mm x 20/6mm 	J S
6mm Oak Layer	300mm x 20/6mm 	J S

J Suitable for
laying over joists

S Suitable over
solid subfloor



American White Oak solid T&G floorboards fitted over floor and stairs

SOLID OAK FLOORING

American White Oak timber is a classic flooring and stair making timber. American White Oak floorboards are available in a range of widths up to 225mm. It is durable, stable, attractive, and sourced sustainably. Natural colours vary from light yellows through to straw.

American White Oak is an ideal timber to use if you are looking for a specific colour – it is a great ‘canvas’ to finish in a coloured oil or stain, which highlights the natural grain magnificently. Solid American White Oak floorboards are usually sanded and finished in place.



128mm x 19mm



J **S**

180mm x 19mm



J **S**

220mm x 19mm



J **S**

J Suitable for laying over joists

S Suitable over solid subfloor



American White Oak Parquet Floor in the Prefab Function Centre, Wellington

OAK PARQUET

Parquet timber floors add an elegant statement to your home, and we have several Oak parquet options that will add a distinctive statement to your home.

We can supply parquet as solid American White Oak or engineered European Oak. The engineered European Oak parquet is usually pre finished, where as the solid American White Oak is usually sanded and finished in place. Both can be finished in a wide variety of beautiful colours.



Engineered European Oak Parquet
Floor Colour: Rubio Monocoat Oil+2C
'Ice Brown'

Engineered European Oak parquet sizes

490mm x 70 x 15/4mm

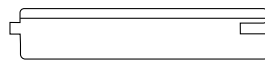

600mm x 120 x 15/4mm



Solid American White Oak parquet size

80 x 19mm



70mm

120mm

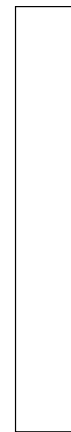

490mm

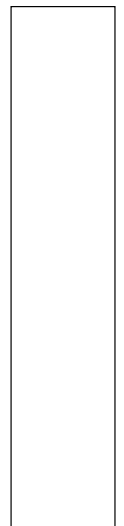

600mm



French Oak Stave Parquet floor in The Petit Tasting Room, Martinborough

FRENCH OAK STAVE PARQUET

Originally used in wine production, and now stunning wooden flooring.

The Oak staves are used to flavour wine. Once used, these staves are often discarded. We have realised the potential in repurposing this beautiful wood and are proud to be able to ensure its journey continues. This clever use of recycled French Oak makes this an unarguably sustainable timber flooring choice.

French Oak stave flooring can be laid in a range of parquet patterns. It is given a light sand followed by a coating of oil. We recommend Rubio Monocoat for its durability and range of colours.

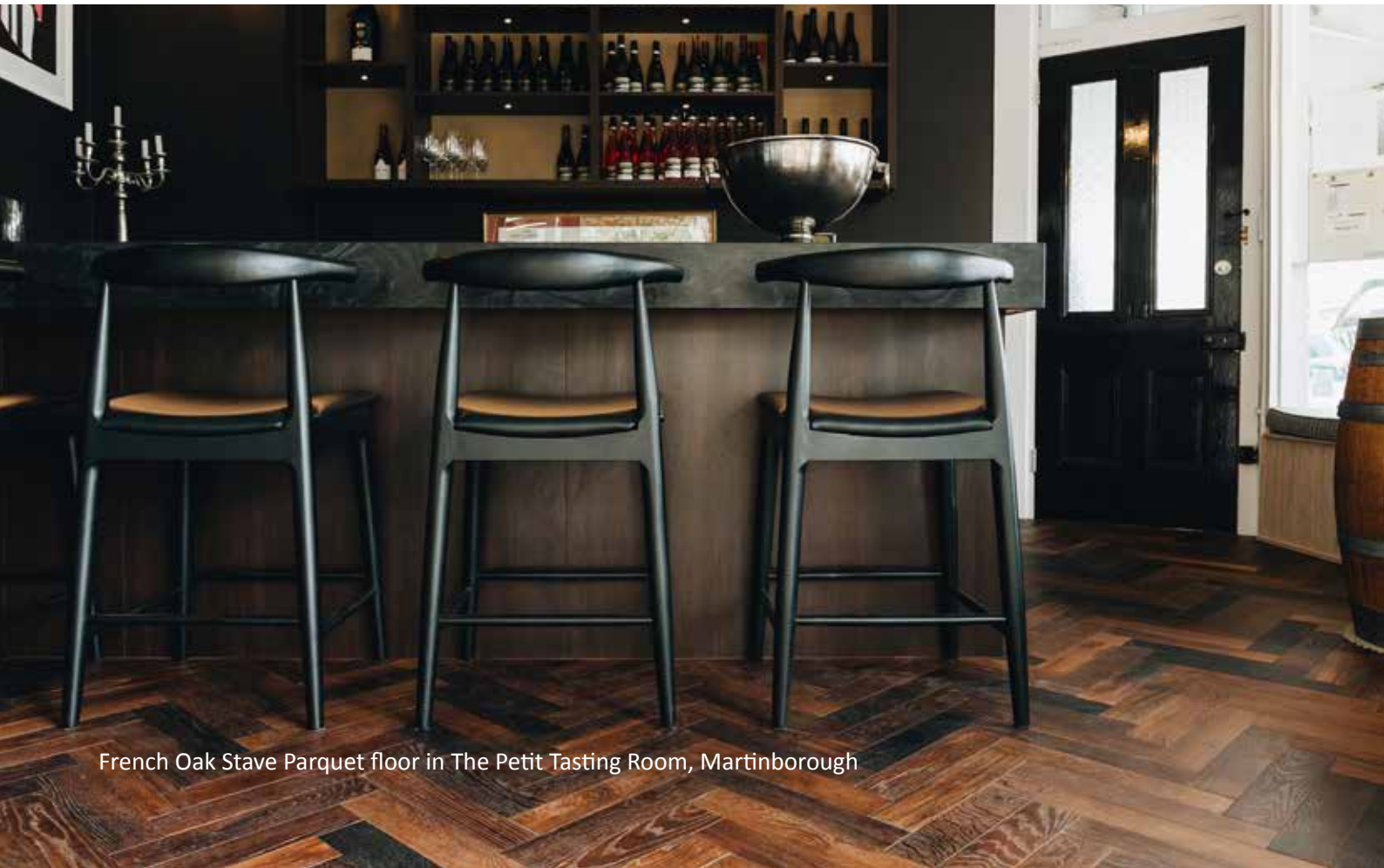

French Oak Stave Parquet floor in The Petit Tasting Room, Martinborough



JAMES HENRY
BEAUTIFUL TIMBER FLOORS

www.jameshenry.co.nz | 04 527 0657

Petone Showroom and Workshop: 5 Cornish St, Petone, Lower Hutt
Petone Hours: 9.00am to 4.00pm, Monday to Friday

Wellington Showroom: Wellington Design Library, 282 Thorndon Quay, Wellington
Wellington Design Library Hours: 9.00am to 5.00pm, Monday to Friday

As we are often out and about visiting clients or onsite, please phone ahead to ensure we are here